



TimeSource 3100

Primary Reference Source For Public Network Service Providers

KEY FEATURES

- Innovative BesTime Clock Engine
- IF Antenna Provides 300 Meter Cable Runs Without Amplifiers
- GPS Holdover Accuracy of 1×10^{-11} for 72 Hours With Optional Inputs
- Timing Accuracy of 100 ns When Locked to GPS
- Base Configuration Includes E1/2.048MHz (2), 10MHz
- 1 PPS, and Time of Day Outputs
- Sync Status Messaging
- Integrated Sync Monitoring of Inputs

INTRODUCTION

Symmetricom's TimeSource® 3100 is a stand alone office Primary Reference Source (PRS) with integrated GPS receiver which meets ITU-T G.811 network performance requirements. The TimeSource 3100 provides undisturbed frequency and time Stratum 1 synchronization when locked to GPS with continued Stratum 1 performance for up to 72 hours upon loss of GPS.

The key to TimeSource 3100's superior performance is its patented multiple input frequency locked loop BesTime™ clock engine. The BesTime engine, GPS receiver, and digitally controlled quartz local oscillator work together to produce precise timing outputs. Span line or remote oscillator inputs can be added, at the user's option, to increase system reliability and holdover performance in the event GPS signals are interrupted.

The GPS antenna can be installed up to 300 meters from the office shelf, without amplifiers, using inexpensive thin coax cable. The TimeSource 3100 can be managed using Symmetricom's TimeScanCraft element manager. The system is CE compliant and provides Sync Status Messaging (SSM).

APPLICATIONS

The TimeSource 3100 system can be configured as a PRS to front-end an office SSU/SASE or as a standalone PRS with 10 outputs for remote or small offices. In the

standalone configuration, TimeSource 3100 provides 10 E1 (2.048 Mb/s or MHz) outputs in a compact, inexpensive package. This configuration is ideal for timing remote switch sites which may also have SDH terminals, or other network elements.

The ESCIU option retimes E1 spans providing improved performance and reduced maintenance for wireless GSM/3G base stations.

The TimeSource 3100 ensures PRS performance is maintained through self-auditing the inputs and measuring and reporting performance against one another. Inputs can be easily provisioned to be either included in the timing ensemble output or be used for monitoring only. The TimeSource 3100 is fully software upgradeable and provisionable while in-service. Communication is via RS-232 or Ethernet ports.



TimeSource 3100

TimeSource 3100 Specifications

GENERAL

- Specifications: ITU-T G.811 and G.812, EN 300 462-6-1, ETSI 3017, CE
- Internal oscillator: Digitally Controlled Ovenized Crystal Oscillator (DCOCXO)
- Sync inputs: GPS, E1/2.048MHz (optional), or remote oscillator (optional)
- Sync outputs: E1/2.048MHz, 10MHz, 1 PPS, TOD, ESCIU
- Sync status messaging: Outputs and inputs
- Communications: RS-232, Ethernet
- Management: TimeScan/Craft, TimeScan/NMS, TimePictra/TMN

E1/2.048 MHz OUTPUTS PERFORMANCE

- Number of outputs: Up to 10 (2 standard)
- Format: 2.048Mb/s G.703/6 (CCS, CAS, CRC4, or non-CRC4 configurable) and 2.048MHz G.703/10 - software selectable
- Frequency accuracy: Locked to GPS 1×10^{-12}
Holdover - no optional inputs: 1×10^{-10} for 24 hours (0° C to 50° C $\pm 5^\circ$ C)
Holdover - with optional inputs: 1×10^{-11} for 72 hours (0° C to 50° C $\pm 5^\circ$ C)

1 PPS OUTPUT PERFORMANCE

- Number of outputs: 1
- Signal type: TTL
- Connector: BNC
- Timing accuracy: Locked to GPS 100 ns to GPS
Holdover - no optional inputs <8.6 μ s to GPS for 24 hours (0° C to 50° C $\pm 5^\circ$ C)
Holdover - with optional inputs <3 μ s to GPS for 72 hours (0° C to 50° C $\pm 5^\circ$ C)

E1/2.048 MHz INPUTS (OPTIONAL)

- Number: 2
- Signal: E1 (G.703/6 and G.703/10 software selectable, bridged or terminated)
- Connector: Wire wrap or BNC

REMOTE OSCILLATOR INPUTS (OPTIONAL)

- Number: 2
- Signal: 5 or 10MHz
- Connector: BNC

TIME OF DAY OUTPUT

- Type: Cisco or NTP IRIG-B (order option)
- Signal: RS-422 Amplitude Modulated
- Connector: RJ-45 BNC

ANTENNA SPECIFICATIONS

- Type: Active antenna with integrated IF downlink
- Cable type: RG-59 with TNC connector
- Cable length: Up to 300 meters without amplifier
- Operating temperature: -30° C to +80° C

OTHER

- Mechanical: 22 cm (H) x 45 cm (W) x 25 cm (D)
- Power: -48 VDC (redundant)
- Operating temperature: 0° C to +50° C
- Humidity: 5% to 95% non-condensing
- EMC: Compliance with FCC Part 15, Class A

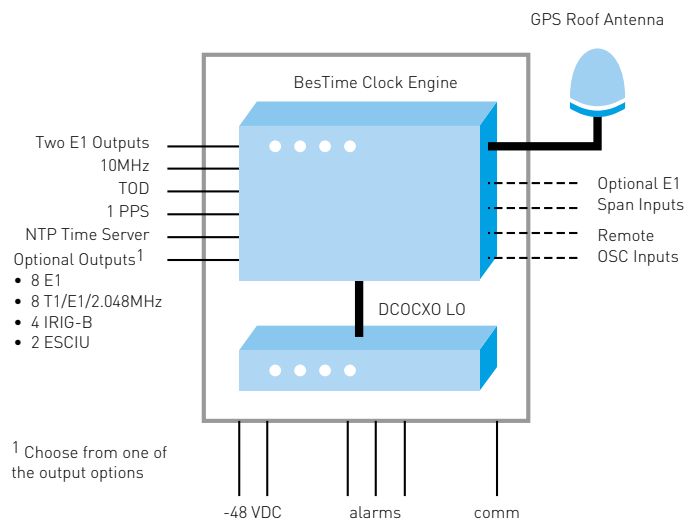

TimeSource 3100 Block Diagram



SYMMETRICOM, INC.
 2300 Orchard Parkway
 San Jose, California
 95131-1017
 tel: 408.433.0910
 fax: 408.428.7896
 info@symmetricom.com
 www.symmetricom.com